



MANDATORY

www.eclipseaerospace.net

ECLIPSE
AEROSPACE

SERVICE BULLETIN

NUMBER: SB 500-53-008, REV B
MODEL: ECLIPSE EA500
SUBJECT: LOWER WING TO BODY FAIRING DRAINAGE

1. PLANNING INFORMATION

A. Effectivity

Aircraft Serial Numbers 0001 - 0300.

B. Reason

Service Bulletin has been prepared to add additional drainage for wing-to-body fairings.

Revision B changes: Changed Service Bulletin type from Recommended to Mandatory.

C. Description

This Service Bulletin provides procedures to install drains (scuppers) in the lower wing-to-body fairings.

D. Relevant Publications

None

E. Compliance

Eclipse Aerospace Inc. considers this to be an mandatory inspection that must be accomplished at the next 300 hour inspection.

F. Approval

This Service Bulletin is based on engineering data that is FAA-approved, and the modification herein complies with the applicable regulations.

G. Labor Requirements

The following information is for planning purposes only.

(1) Estimated labor hours to perform:

Suggested number of personnel: 1

Job Set-up and Job Close-up: 3.0 Hours

Rework: 3.0 Hours

Total labor hours: 6.0

The above is an estimate based on properly equipped and experienced personnel complying with this Service Bulletin. Actual labor hours may vary depending on workforce experience, concurrent maintenance, discovery of other discrepancies, etc. This estimate is based on aircraft without an ADF Installation. Add an additional 2 hours if ADF Antenna is installed.

(2) Qualification of personnel:

- A person properly authorized under 14 CFR 43 to perform aircraft maintenance.

H. Weight and Balance Change

Negligible



MANDATORY

ECLIPSE
AEROSPACE

SERVICE BULLETIN

I. Electrical Load Data Change

None

J. References

Aircraft Maintenance Manual (AMM), P/N 06-117751, latest revision.

K. Publications Affected

None

2. MATERIAL INFORMATION

A. Materials

Order parts below:

Item	Part Number	Description	Qty	Unit of Issue
1, Figure 4, Sheet 3	AN231-4	Grommet-Drainage, Plastic	10	EA.

B. Consumables

The following consumables are required for this Service Bulletin.

Material	Specification	Use
Adhesive	Scotchweld 2216	Rework
Corrosion Preventive Compound	MIL-PRF-16173, Class I or II, Grade 1 or 4	Corrosion preventive
Abrasive Pad	Scotchbrite 120 Grit	Cleaning
Epoxy Resin	Hysol EA 9396	Edge dressing
Cleaning Solvent	Isopropyl Alcohol	Cleaning
Sealant	PRC Desoto PR-2001	Seal ADF antenna (if installed)
Tie Strap	MS3367-1-9	Secure ADF antenna harness (if installed)
Primer	MIL-PRF-85582	Prep surface for topcoat
Topcoat Polyurethane Paint	CA8800/11050	Touch-up exterior paint

C. Tooling

The following special tooling/support equipment is required to accomplish this Service Bulletin.

Nomenclature	Specification	Use
Heat Gun	Proheat, PH1200 or equivalent	Drain grommet removal
Drill Bits	Carbide, sizes up to 0.5 inch diameter	Fairing rework



MANDATORY

ECLIPSE
AEROSPACE

SERVICE BULLETIN

D. Interchangeability/Intermixability of Parts

None.

E. Part Re-identification

Mark reworked wing-to-body fairings "Modified by SB 500-53-008"

3. ACCOMPLISHMENT INSTRUCTIONS

A. Procedure

SIGN OFF

(1) Job Set-up,

- (a) Make the aircraft safe for maintenance. Refer to AMM - 20-00-01 - MAKE SAFE FOR MAINTENANCE. _____
- (b) Remove Left Lower Wing-to-Body Fairing - 251 EL. Refer to AMM - 53-11-11 - LOWER WING TO BODY FAIRING ASSEMBLY - REMOVAL. _____
- (c) Remove Right Lower Wing-to-Body Fairing - 252 DR. Refer to AMM - 53-11-11 - LOWER WING TO BODY FAIRING ASSEMBLY - REMOVAL. _____
 - 1. If installed, remove ADF components as follows:
 - a. Remove two screws (1, Figure 1, Sheet 1) that secure the external ADF antenna (2, Figure 1, Sheet 1) to Right Lower Wing-to-Body Fairing - 252 DR. _____
 - b. Lower external ADF antenna (2, Figure 1, Sheet 1) and disconnect electrical connector (3, Figure 1, Sheet 1). Remove ADF antenna from the Right Lower Wing-to-Body Fairing - 252 DR. _____
 - c. Remove Right Lower Wing-to-Body Fairing - 252 DR. Refer to AMM - 53-11-11 - LOWER WING TO BODY FAIRING ASSEMBLY - REMOVAL. _____
 - d. Cut and remove the tie strap the secures the ADF wiring harness to the cable mount. _____
 - e. Remove four screws (3, Figure 1, Sheet 2) that secure the internal ADF antenna grounding plate (7, Figure 1, Sheet 2) to the Right Lower Wing-to-Body Fairing - 252 DR. _____
 - f. Separate the gasket (4, Figure 1, Sheet 2) and the internal ADF antenna grounding plate (7, Figure 1, Sheet 2) from the Right Lower Wing-to-Body Fairing - 252 DR. _____



MANDATORY

ECLIPSE
AEROSPACE

SERVICE BULLETIN

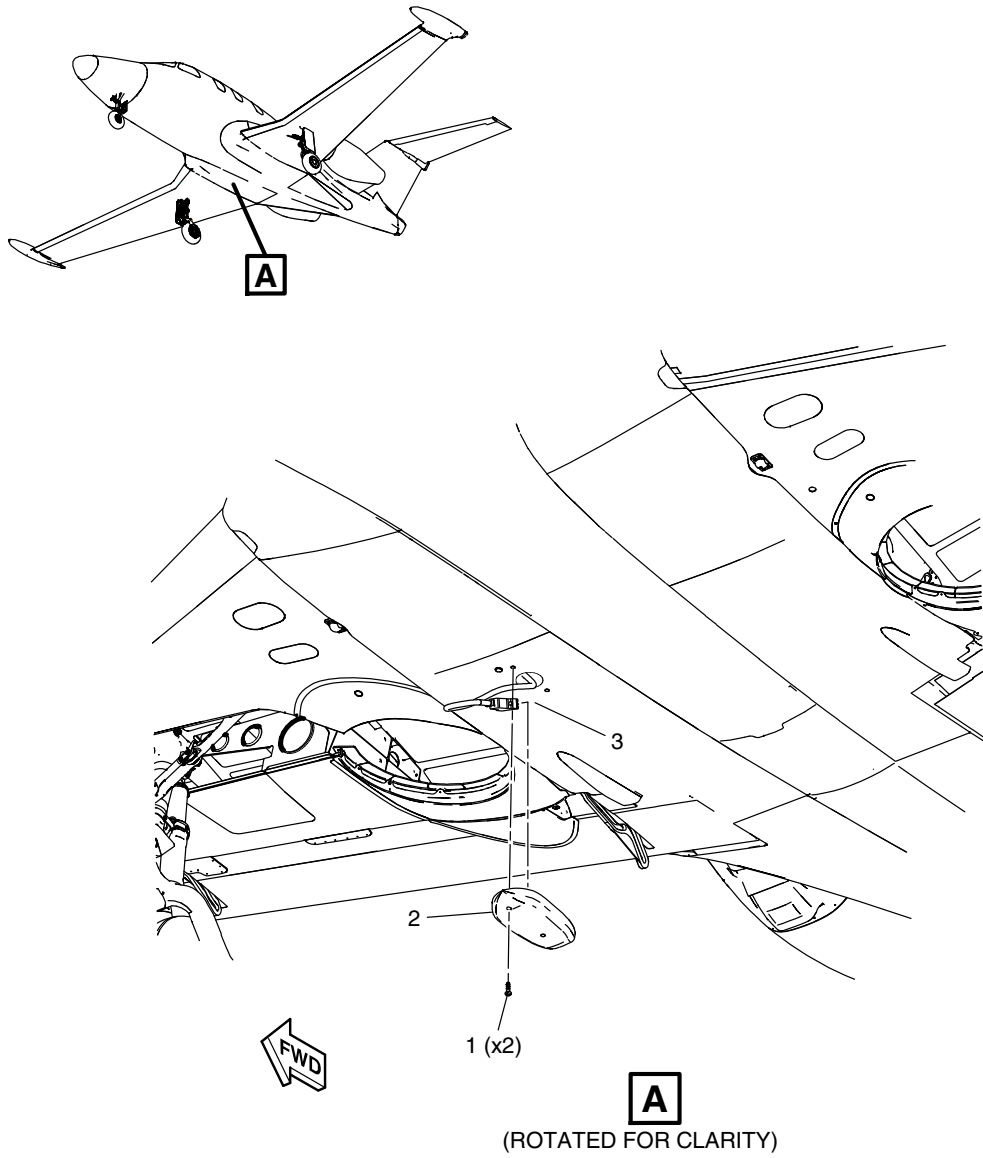

5080861C

ADF Installation
Figure 1 (Sheet 1 of 2)



ECLIPSE
AEROSPACE

SERVICE BULLETIN

OPTIONAL

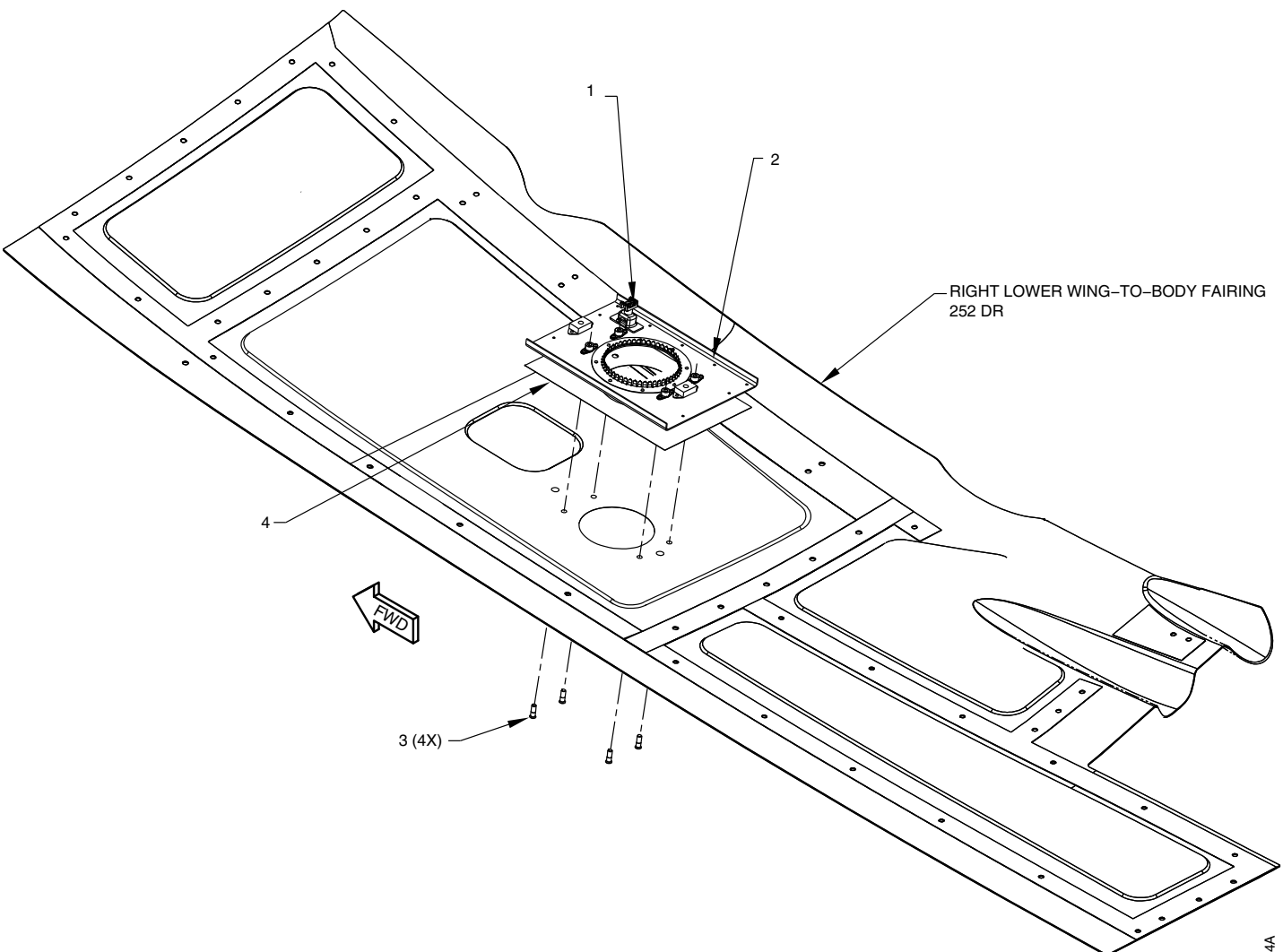

ADF Installation
Figure 1 (Sheet 2 of 2)



SERVICE BULLETIN

SIGN OFF

- (d) Remove Left Aft Wing-to-Body Fairing - 251 FL. Refer to AMM - 53-11-13 - AFT WING TO BODY FAIRING - REMOVAL. _____
- (e) Remove Right Aft Wing-to-Body Fairing - 252 EL. Refer to AMM - 53-11-13 - AFT WING TO BODY FAIRING - REMOVAL. _____
- (2) **Rework Lower Wing-to-Body Fairings**
 - (a) Inspect lower wing-to-body fairings for corrosion. Replace any corroded removable parts if found. Clean corrosion from lower wing-to-body fairing composite surface. _____
 - (b) Perform inspection (tapping) to assure no delamination exists in the lower wing-to-body fairings. _____
 - (c) If installed, lightly polish discolored/corroded ADF antenna copper foil with Scotch Brite pad to remove all discoloration and or corrosion (Right Aft Wing-to-Body Fairing - 252 EL only). _____
 - (d) If severe corrosion is found on copper foil, replace copper foil P/N CFL-5A as follows:
 - 1. Remove all copper foil and gaskets from Right Aft Wing-to-Body Fairing - 252 EL. _____
 - 2. Clean corrosion from Right Aft Wing-to-Body Fairing - 252 EL composite surface. _____
 - 3. Locate and apply CFL-5A copper foil sheet (18" x 16" approximately) to panel. Make sure sheet completely covers area under gasket perimeter. Trim copper sheet as required to fit panel. Refer to (Figure 2, Sheet 3). _____

NOTE: If air bubbles are present after installing copper sheet P/N CFL-5A , it is permissible to perforate copper sheet to remove trapped air bubbles. Press copper sheet back into place after releasing air bubbles.

 - 4. Locate and punch/cut out holes to match fairing fastener holes and antenna penetration. _____
 - 5. Install grounding plate and gasket P/N 39-122415-2001 using four screws P/N NAS8703-4 onto Right Aft Wing-to-Body Fairing - 252 EL. _____
 - 6. Check for electrical bond between ADF antenna grounding plate and copper tape. Resistance must be 2.5 milliohms or less. _____
 - 7. Remove plastic protective covers from gaskets. Install grounding gaskets (P/N 39-122418-2001, 39-122440-2001, and 39-122441-2001) onto Right Lower Wing-to-Body Fairing - 252 DR. Refer to (Figure 2, Sheet 3) and (Figure 2, Sheet 2). _____
 - 8. Secure gaskets in place with strips of copper sheet P/N CFL-5A cut into 0.75 inch wide strips. Cover with plastic strips until ready to install fairing. Refer to (Figure 2, Sheet 3) and (Figure 2, Sheet 2). _____



MANDATORY

ECLIPSE
AEROSPACE

SERVICE BULLETIN

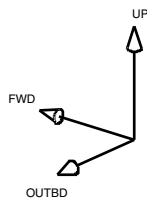
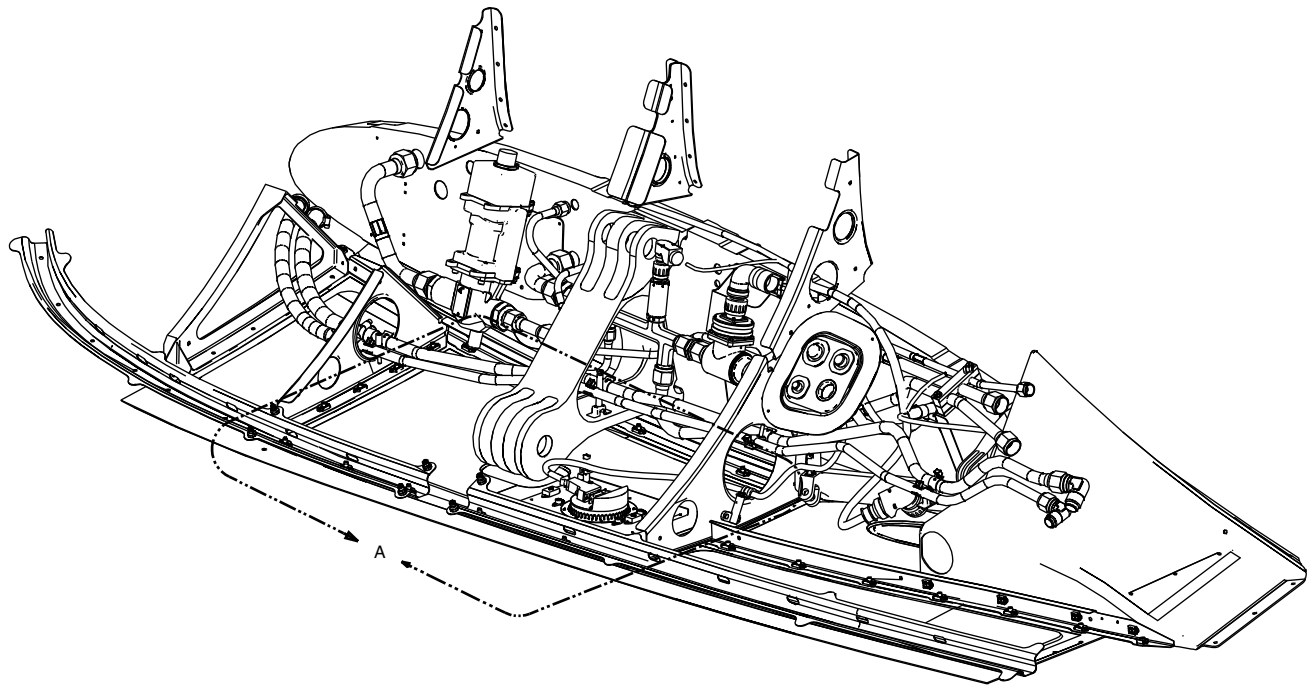

3D MAIN VIEW
(VIEW ROTATED)
STRUCTURE REMOVED FOR CLARITY

ADF Gaskets and Copper Foil
Figure 2 (Sheet 1 of 3)

5121569A



MANDATORY

ECLIPSE
AEROSPACE

SERVICE BULLETIN

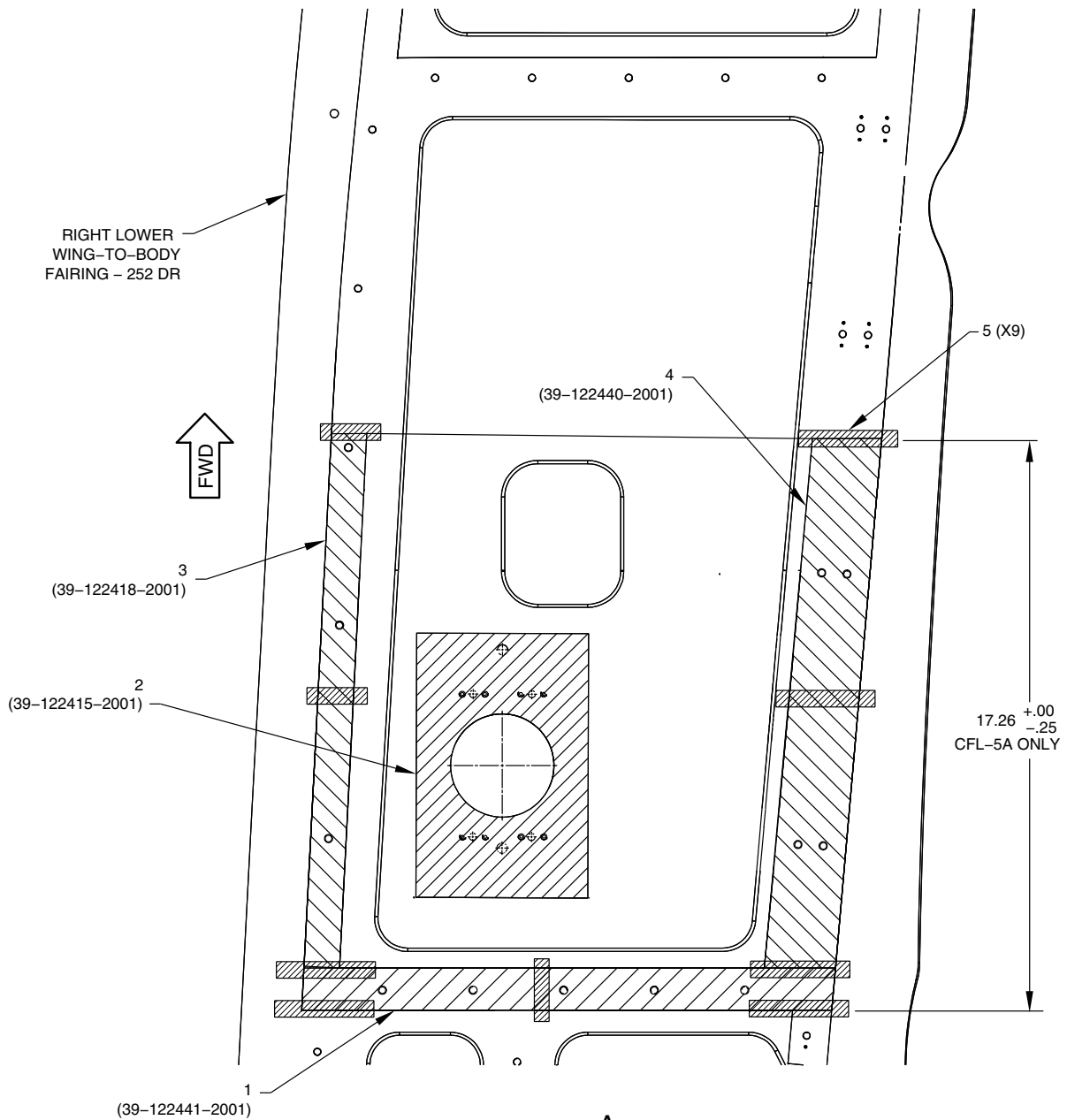

VIEW A
(STRUCTURE REMOVED FOR CLARITY)
(VIEW LOOKING DOWN)

5121568A

ADF Gaskets and Copper Foil
Figure 2 (Sheet 2 of 3)



SERVICE BULLETIN

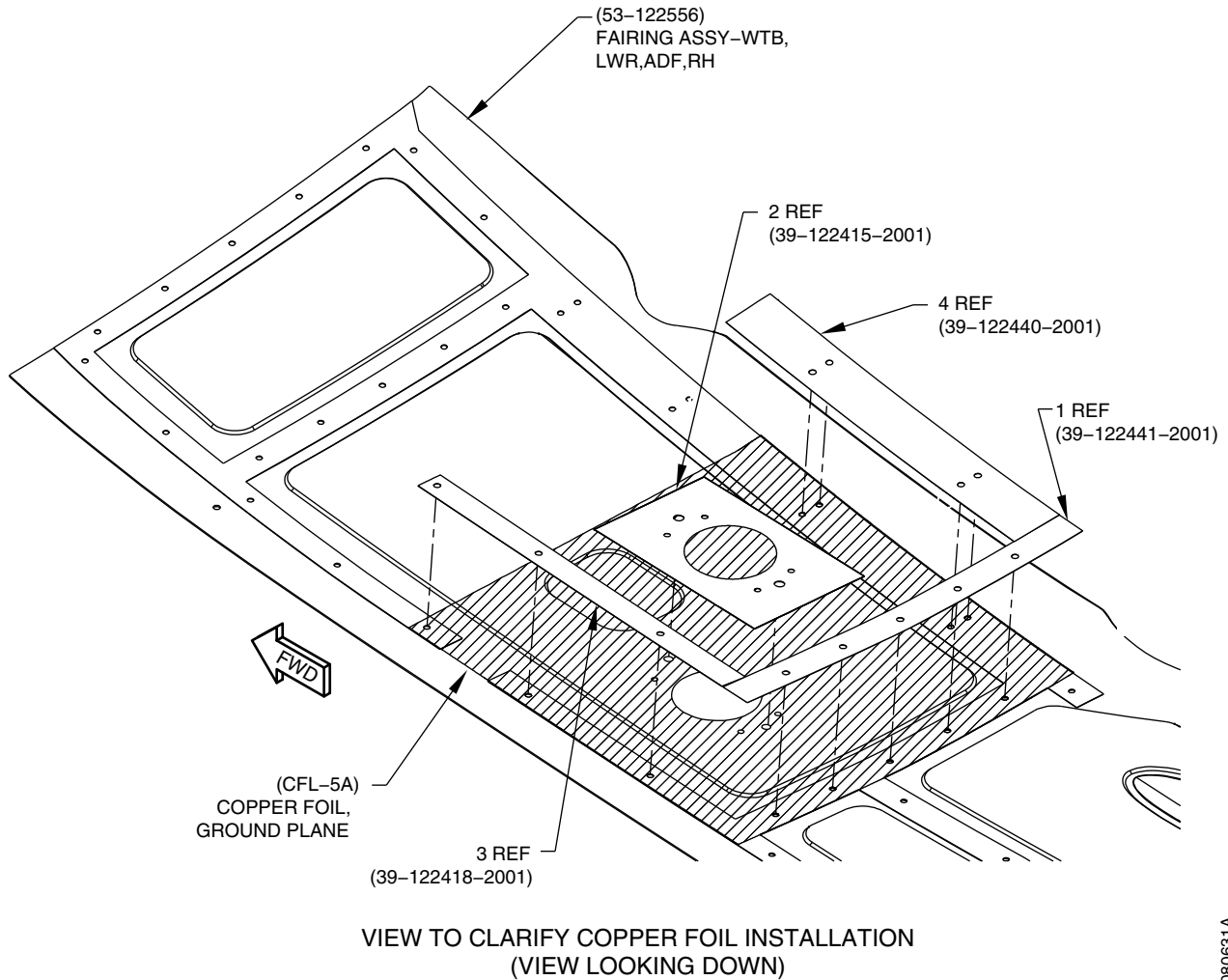

5080631A

ADF Gaskets and Copper Foil Figure 2 (Sheet 3 of 3)

SIGN OFF

- (e) Apply corrosion preventive compound, MIL-PRF-16173 Class I or II, Grade 1 or 4 on the exposed copper foil (optional ADF Installation). Do not apply to gasket areas represented by hatched lines. Refer to 1, 2, 3, 4, Figure 2, Sheet 2.
- (f) Remove and discard existing drain grommets that are installed on the fairing panel's inner surface. Refer to Figure 3.

CAUTION: Do not use higher temperature than what is listed. Damage to the laminate skin can occur.

1. Set the heat gun temperature to 250° F.
2. Heat the inner surface around the perimeter of the drain grommet location, maintaining a distance of 2-5 inches between the heat gun and the drain grommet location.



SERVICE BULLETIN

SIGN OFF

- 3. While heating the area, use a sharpened putty knife to carefully scrape excess squeeze-out of epoxy on the lower wing-to-body fairing's inner surface.
- 4. Once the adhesive has softened sufficiently, use the sharpened putty knife to separate the drain grommet from the composite lower wing-to-body fairings by tapping the handle of the putty knife with a hammer as the blade is positioned around the edge of the drain grommet perimeter. Work the putty knife carefully around the perimeter evenly to remove the drain grommets.

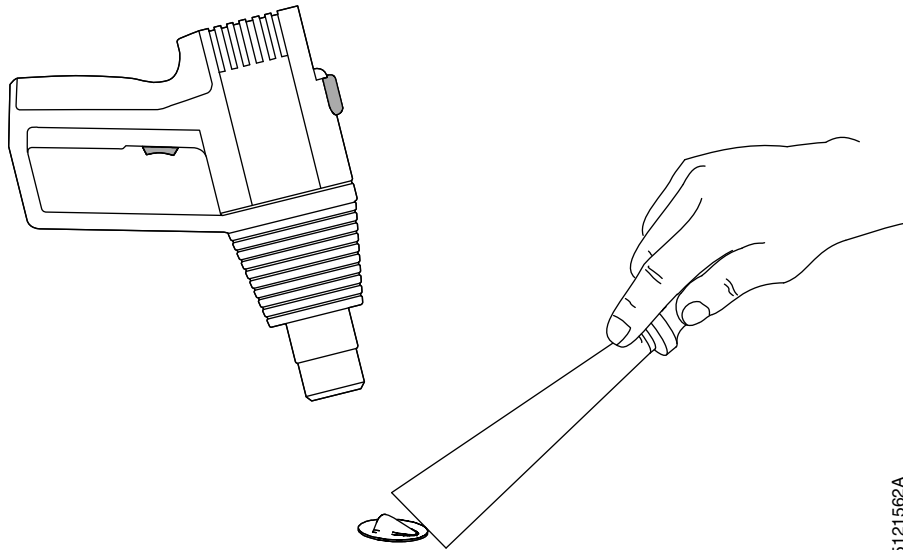

5121562A

**Drain Grommet Removal
Figure 3**

- 5. Remove the remaining epoxy from the mating surface of the composite lower wing-to-body fairings by sanding the mating areas with 120 grit Scotch-Brite pad. Sand an area around the hole that is between 0.75 and 1.25 inches in diameter.
- 6. Clean inner surface with isopropyl alcohol where the removed drain grommets existed and touch-up surface with epoxy resin P/N Hysol EA 9396.
- (g) On lower wing-to-body fairings enlarge existing drain grommet hole from 0.25 inch diameter to 0.50 inch diameter. Refer to [Figure 4, Sheet 1](#) and [Figure 4, Sheet 2](#).

NOTE: To avoid fraying and tear-out, use backer block applied to exterior of panel and step drill holes with carbide bits drilling from the interior. Start with smaller carbide bit and progress to 0.50 inch diameter carbide bit.

- (h) Seal edges of the opened drainage hole with epoxy resin P/N Hysol EA 9396.



MANDATORY

ECLIPSE
AEROSPACE

SERVICE BULLETIN

SIGN OFF

- (i) Drill a 0.50 inch diameter hole through the pocket as shown in (Figure 4, Sheet 1) (LH) and (Figure 4, Sheet 2) (RH).

NOTE: To avoid fraying and tear-out, use backer block applied to exterior of panel and step drill holes with carbide bits drilling from the interior. Start with smaller carbide bit and progress to 0.50 inch diameter carbide bit.

NOTE: If ADF antenna is installed, drill through copper foil.

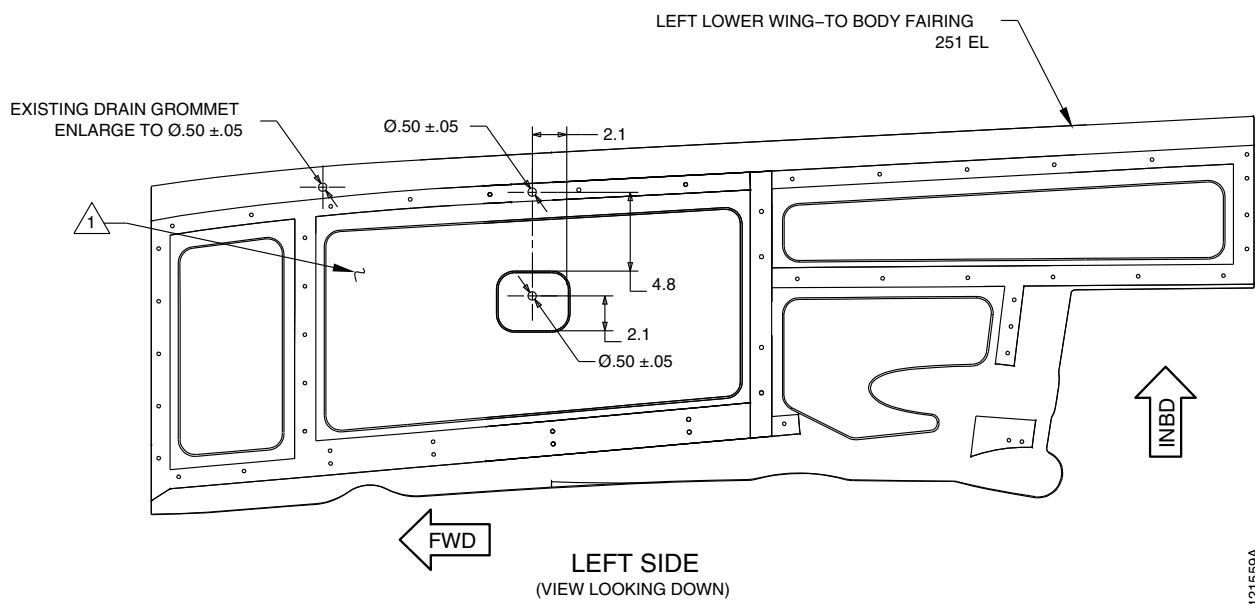

**Left Lower Wing-to-Body Fairing (Interior)
Figure 4 (Sheet 1 of 4)**



MANDATORY

ECLIPSE
AEROSPACE

SERVICE BULLETIN

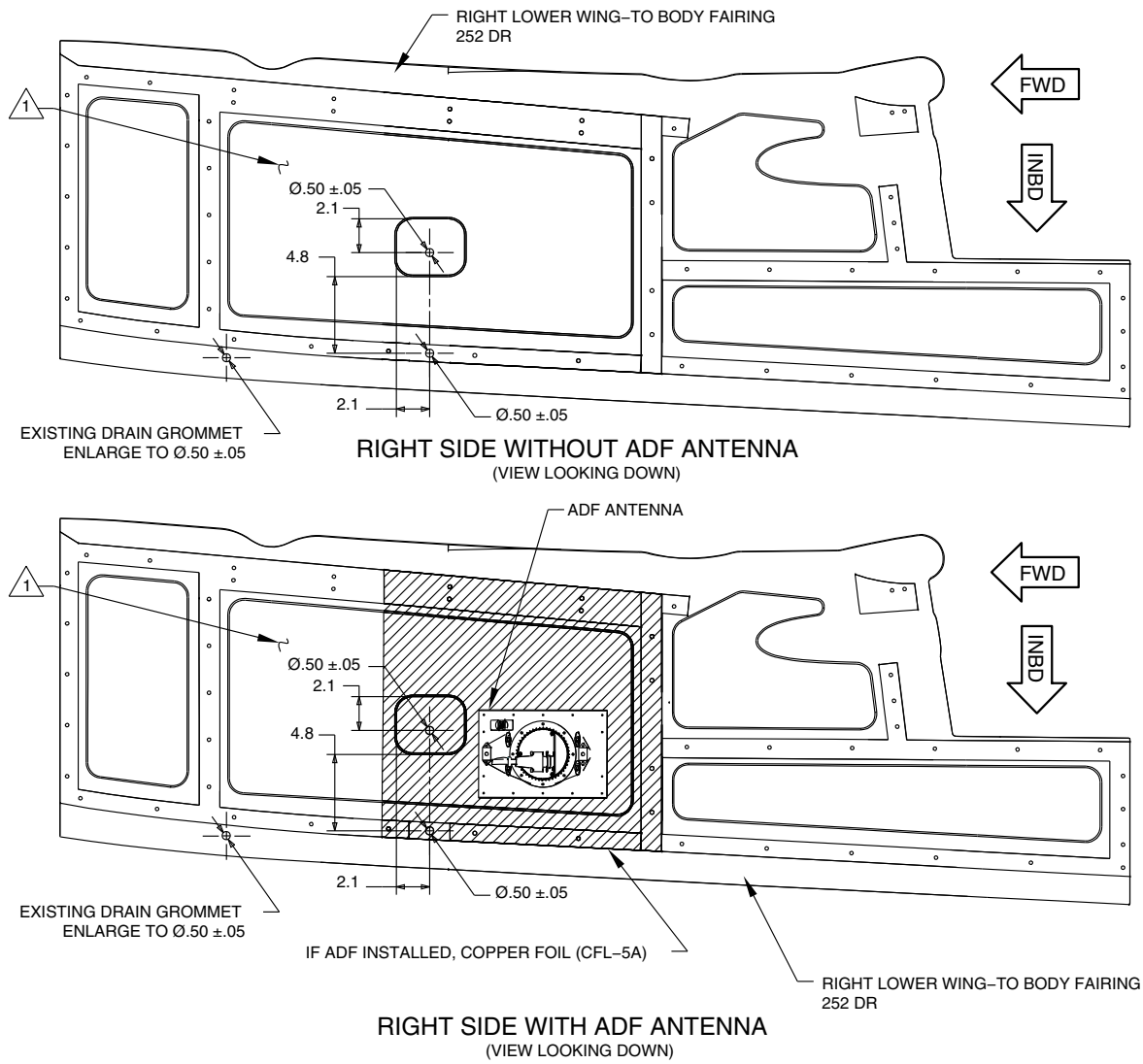

Right Lower Wing-to-Body Fairing (Interior)
Figure 4 (Sheet 2 of 4)



MANDATORY

ECLIPSE
AEROSPACE

SERVICE BULLETIN

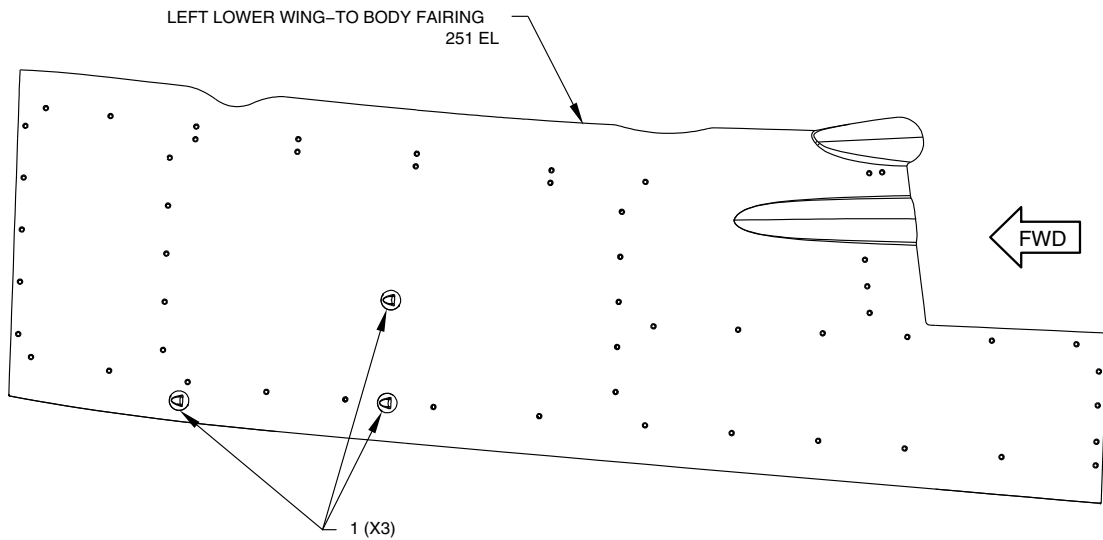

LEFT SIDE
(VIEW LOOKING UP)

5121567A

**Left Lower Wing-to-Body Fairing (Exterior)
Figure 4 (Sheet 3 of 4)**



MANDATORY

ECLIPSE
AEROSPACE

SERVICE BULLETIN

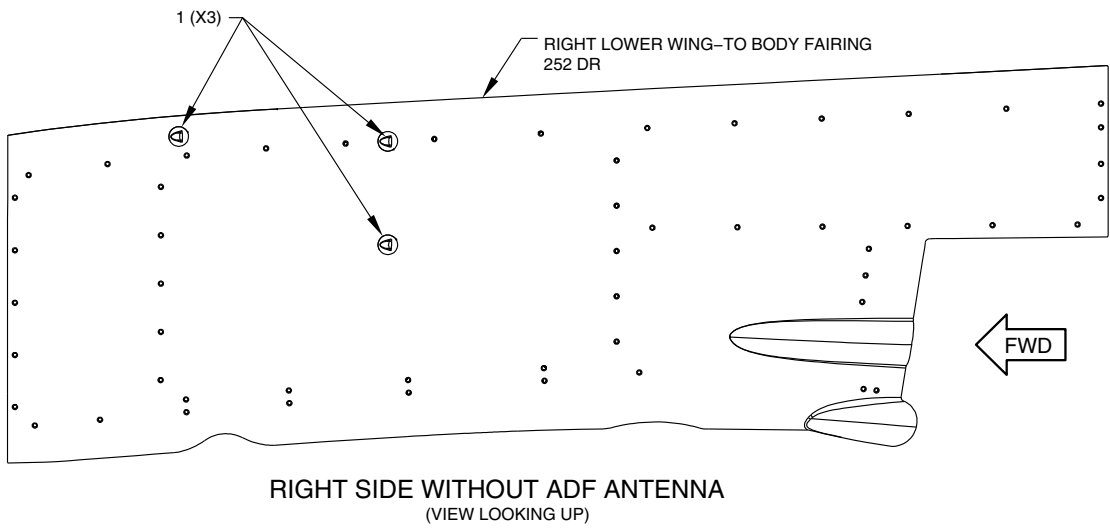
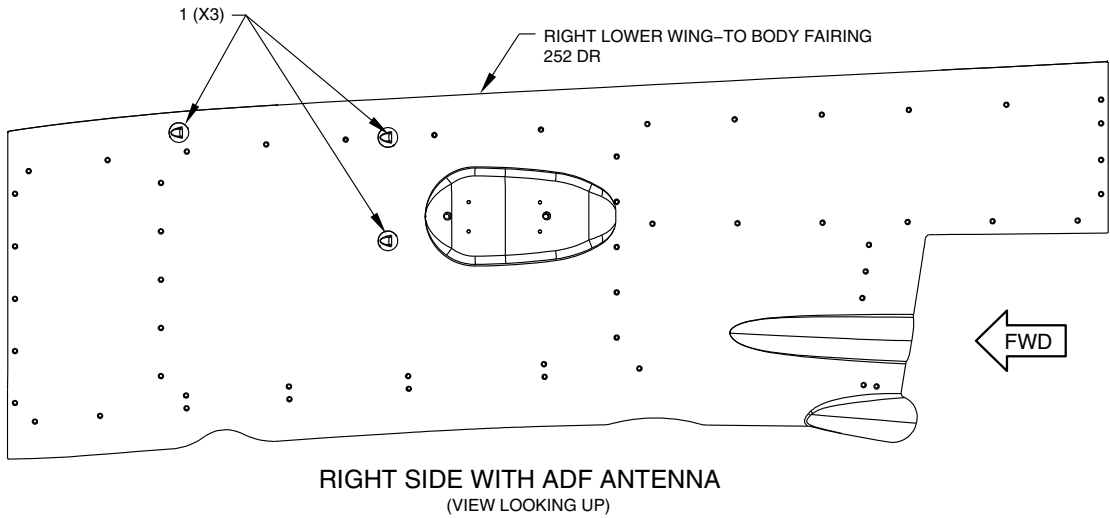

5121566A

**Right Lower Wing-to-Body Fairing (Exterior)
Figure 4 (Sheet 4 of 4)**

SIGN OFF

- (j) Drill a 0.50 inch diameter hole on the inboard edge of the lower wing-to-body fairing as shown in (Figure 4, Sheet 1) (LH) and (Figure 4, Sheet 2) (RH).

NOTE: If ADF antenna is installed, drill through copper foil.

NOTE: To avoid fraying and tear-out, use backer block applied to exterior of lower wing-to-body fairings and step drill holes with carbide bits drilling from the interior. Start with smaller carbide bit and progress to 0.50 inch diameter carbide bit.



MANDATORY

ECLIPSE
AEROSPACE

SERVICE BULLETIN

SIGN OFF

- (k) Seal edges of the drain holes with epoxy resin P/N Hysol EA 9396. Do not allow epoxy resin to contact copper sheet (if installed). _____
- (l) Bond three drainage grommets P/N AN231-4 drainage grommets on the outer surface of the lower wing-to-body fairings using Scotchweld 2216. _____
 - 1. Locate all drainage grommets P/N AN231-4 centered on the drain hole +/- 0.06 inch with the opening facing aft +/- 10 degrees. _____
- (m) Touch-up bare composite with primer and topcoat as necessary. Refer to AMM - 20-09-00 - AIRCRAFT FINISHES. _____
- (n) Mark left and right lower wing-to-body fairings "Modified by SB 500-53-008" with indelible ink in location shown by [Flag Note 1, Figure 4, Sheet 1](#) and [Flag Note 1, Figure 4, Sheet 2](#). _____
- (o) If previously installed, assemble ADF components as follows:
 - 1. Connect electrical connector to ADF antenna and install ADF antenna onto Right Lower Wing-to-Body Fairing - 252 DR. Secure ADF harness to cable mount ([6, Figure 1, Sheet 2](#)) with a tie strap P/N MS3367-1-9. _____
 - 2. Secure external ADF antenna ([2, Figure 1, Sheet 1](#)) with two screws ([1, Figure 1, Sheet 1](#)) to Right Lower Wing-to-Body Fairing - 252 DR. _____
 - 3. Fillet seal ADF antenna to Right Lower Wing-to-Body Fairing - 252 DR with Sealant P/N PRC Desoto PR-2001. _____
 - 4. Check resistance from antenna's top circular electronics module to copper foil plane. Resistance should be 2.5 milliohms or less. _____
- (p) Install Right Lower Wing-to-Body Fairing - 252 DR. Refer to AMM - 53-11-11 - LOWER WING TO BODY FAIRING ASSEMBLY - INSTALLATION. _____
- (q) Install Left Lower Wing-to-Body Fairing - 251 EL. Refer to AMM - 53-11-11 - LOWER WING TO BODY FAIRING ASSEMBLY - INSTALLATION. _____
- (3) Rework Aft Wing-to-Body Fairings**
 - (a) Inspect aft wing-to-body fairings for corrosion. Replace any corroded removable parts if found. Clean corrosion from aft wing-to-body fairing's composite surface. _____
 - (b) Perform inspection (tapping) to assure no delamination exists in the aft wing-to-body fairings. _____
 - (c) Remove and discard existing drain grommets that are installed on the aft wing-to-body fairing's inner surface. Refer to [Figure 5, Sheet 1](#). _____



MANDATORY

ECLIPSE
AEROSPACE

SERVICE BULLETIN

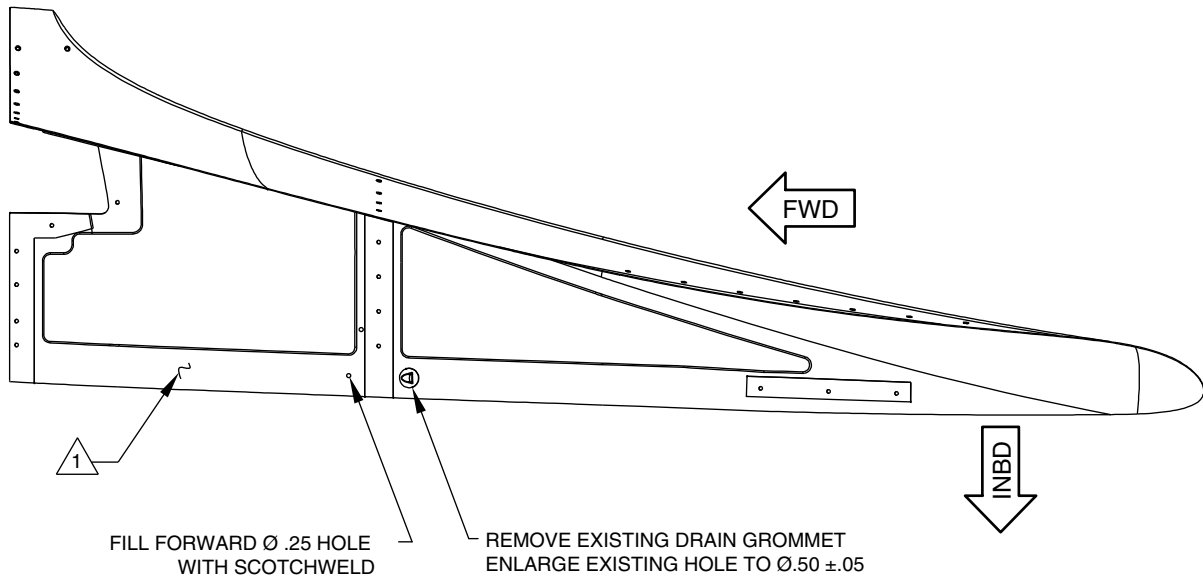

RIGHT AFT WING-TO-BODY FAIRING 252 EL
VIEW LOOKING DOWN

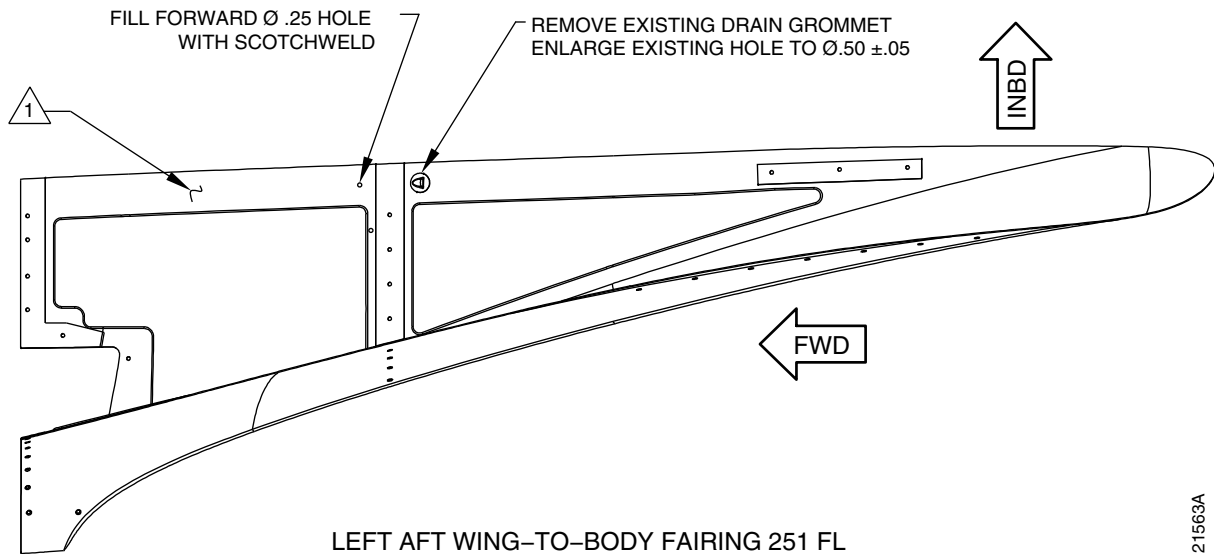

LEFT AFT WING-TO-BODY FAIRING 251 FL
VIEW LOOKING DOWN

Aft Wing-to-Body Fairings
Figure 5 (Sheet 1 of 2)

5121563A



MANDATORY

ECLIPSE
AEROSPACE

SERVICE BULLETIN

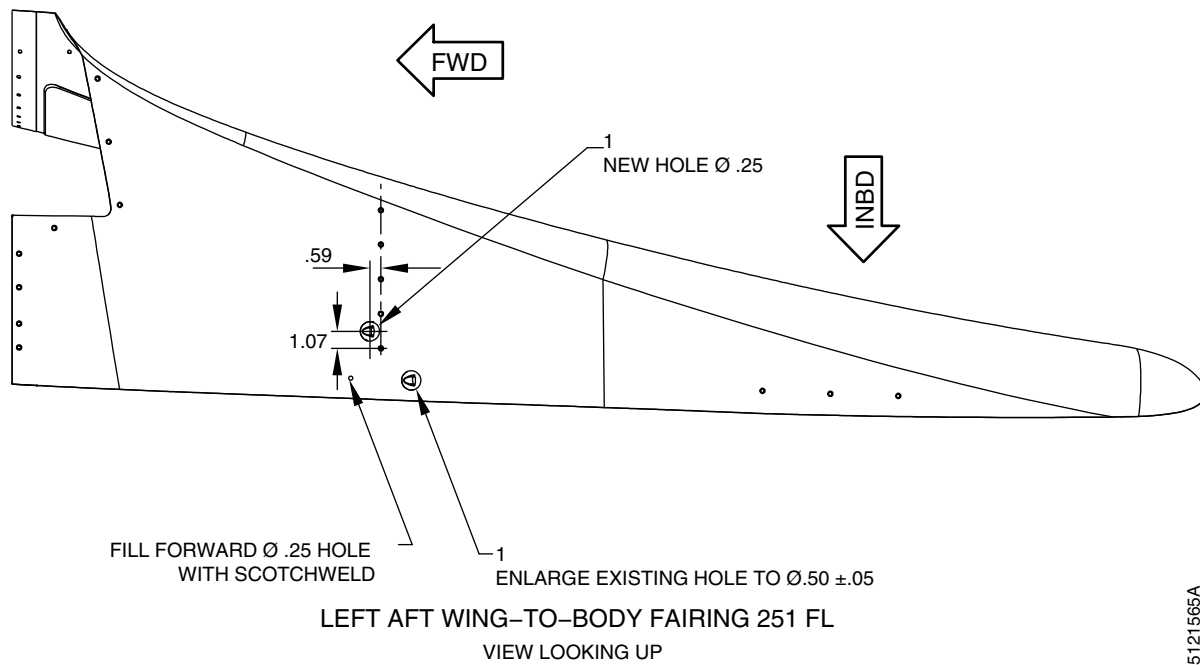
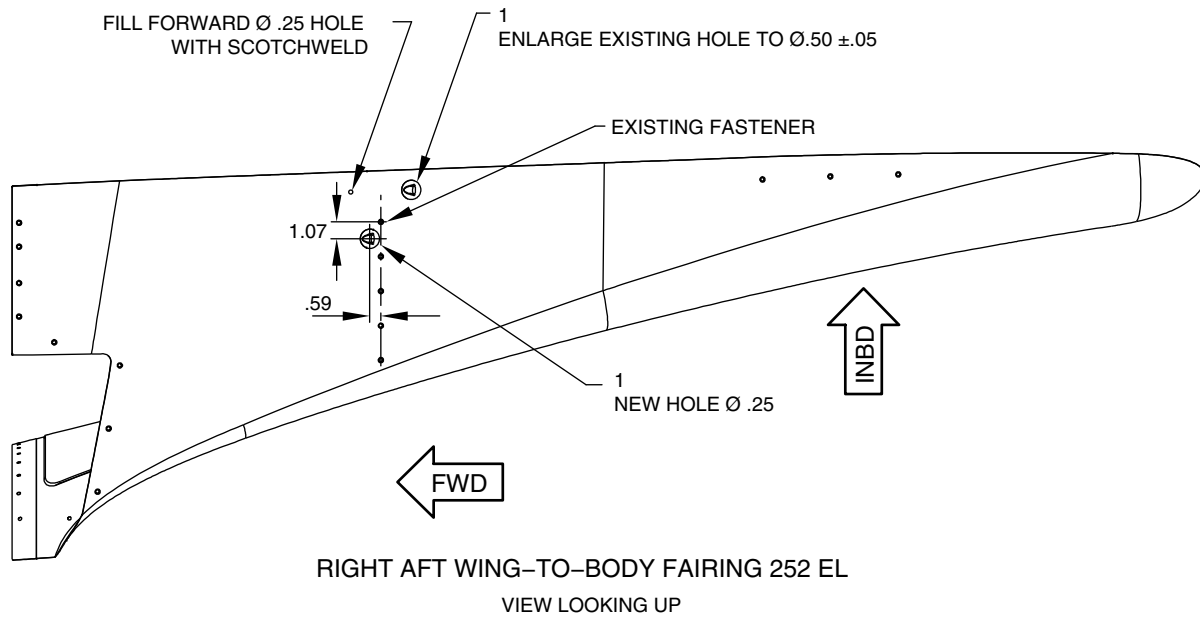

**Aft Wing-to-Body Fairings
Figure 5 (Sheet 2 of 2)**

5121565A



SERVICE BULLETIN

SIGN OFF

CAUTION: Do not use higher temperature than what is listed.
Damage to the laminate skin can occur.

1. Set the heat gun temperature to 250° F. _____
2. Heat the inner surface around the perimeter of the drain grommet location, maintaining a distance of 2-5 inches between the heat gun and the drain grommet location. _____
3. While heating the area, use a sharpened putty knife to carefully scrape excess squeeze-out of epoxy on the aft wing-to-body fairing's inner surface. _____
4. Once the adhesive has softened sufficiently, use the sharpened putty knife to separate the drain grommet from the composite aft wing-to-body fairings by tapping the handle of the putty knife with a hammer as the blade is positioned around the edge of the drain grommet perimeter. Work the putty knife carefully around the perimeter evenly to remove the drain grommets. _____
5. Remove the remaining epoxy from the mating surface of the composite aft wing-to-body fairings by sanding the mating areas with 120 grit Scotch-Brite pad. Sand an area around the hole that is between 0.75 and 1.25 inches in diameter. _____
6. Clean inner surface with isopropyl alcohol where the removed drain grommet existed and touch-up surface with epoxy resin P/N Hysol EA 9396. _____

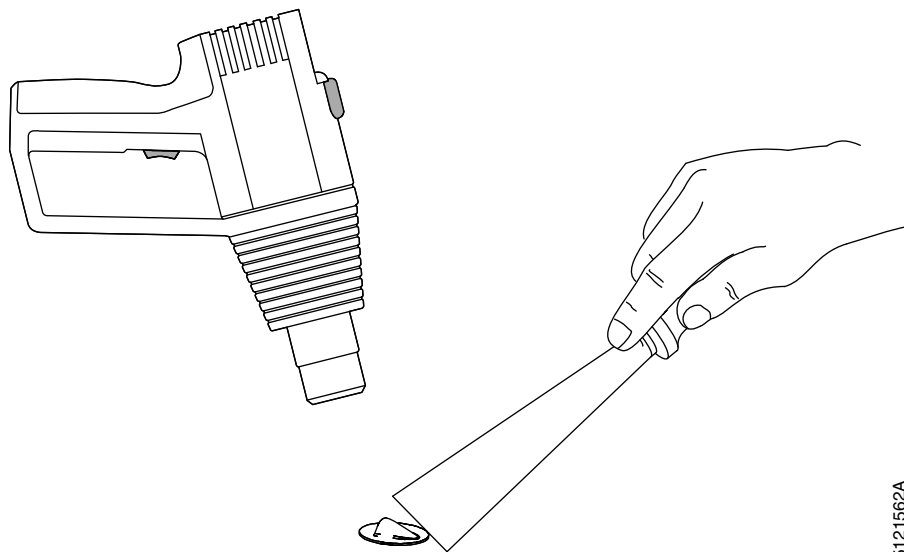

5121562A

**Drain Grommet Removal
Figure 6**



SERVICE BULLETIN

SIGN OFF

- (d) On aft wing-to-body fairings enlarge existing aft drain grommet hole from 0.25 inch diameter to 0.50 inch diameter. Refer to [Figure 5, Sheet 1](#).

NOTE: There are two holes located aft of the aft wing-to-body fairings. Enlarge the aft hole only.

NOTE: To avoid fraying and tear-out, use backer block applied to exterior of panel and step drill holes with carbide bits drilling from the interior. Start with smaller carbide bit and progress to 0.50 inch diameter carbide bit.

- (e) Drill new 0.25" diameter hole. Refer to [Figure 5, Sheet 2](#).

NOTE: To avoid fraying and tear-out, use backer block applied to exterior of panel and step drill holes with carbide bits drilling from the interior. Start with smaller carbide bit and progress to 0.25 inch diameter carbide bit.

- (f) Fill existing forward hole with Scotchweld 2216.

1. Allow Scotchweld 2216 to cure, lightly sand and apply primer and topcoat. Refer to AMM - 20-09-00 - AIRCRAFT FINISHES.

- (g) Seal edges of the opened drainage holes with epoxy resin P/N Hysol EA 9396.

- (h) Bond two new drainage grommets P/N AN231-4 ([1, Figure 5, Sheet 2](#)) on the outer surface of the aft wing-to-body fairings using Scotchweld 2216.

1. Locate drainage grommets P/N AN231-4 centered on the drain hole +/- 0.06 inch with the opening facing aft +/- 10 degrees.

- (i) Touch-up bare composite with primer and topcoat as necessary. Refer to AMM - 20-09-00 - AIRCRAFT FINISHES.

- (j) Mark left and right aft wing-to-body fairings "Modified by SB 500-53-008" with indelible ink in location shown by [Flag Note 1, Figure 5, Sheet 1](#).

- (k) Install Left Aft Wing-to-Body Fairing - 251 FL. Refer to AMM - 53-11-13 - AFT WING TO BODY FAIRING - INSTALLATION.

- (l) Install Right Aft Wing-to-Body Fairing - 252 EL. Refer to AMM - 53-11-13 - AFT WING TO BODY FAIRING - INSTALLATION.

(4) Adjustment/Test

- (a) If equipped with ADF System. Perform Adjustment/Test of the ADF System. Refer to AMM - 34-50-50 - ADF - ADJUSTMENT/TEST.

(5) Job Close-up

- (a) If all other maintenance is complete, return the aircraft to service. Refer to the AMM - 20-00-02 - RETURN TO SERVICE (AFTER MAINTENANCE).



MANDATORY

ECLIPSE
AEROSPACE

SERVICE BULLETIN

B. Limitations and Procedures

None

C. Cost

Contact Eclipse Aerospace Inc. for cost and availability.

4. RECORD OF COMPLIANCE

Upon completion of this Service Bulletin, make an appropriate maintenance-record entry specifying the Service Bulletin number.

5. NOTIFYING ECLIPSE AEROSPACE

On completing this service bulletin, the operator/maintainer shall complete the attached Compliance Record and send it to Eclipse Aerospace via regular mail, fax, or e-mail.

Mailing Address	Eclipse Aerospace Incorporated ATTN: Customer Care 2503 Clark Carr Loop SE Albuquerque, NM 87106
Fax	1-505-241-8802
E-mail	customerfirstteam@eclipse.aero

